

GENERAL FITTING GUIDE - FIRECLAY KITCHEN SINKS

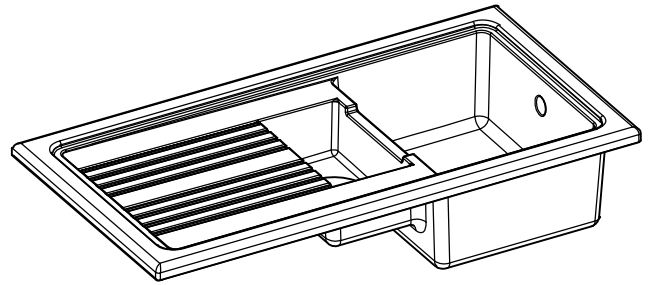
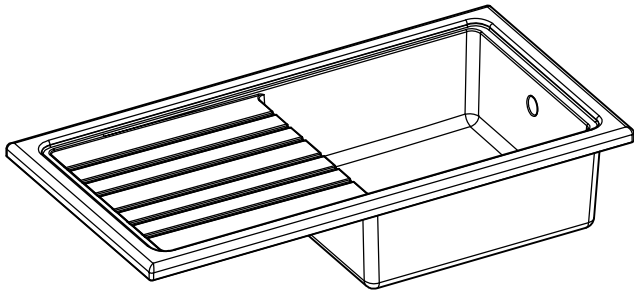

TOOLS REQUIRED

Ruler/Tape Measure	Pencil or Non-Permanent Marker
Masking Tape	Safety Glasses and Gloves
Kitchen Silicone Sealant	Screwdriver
Hammer	Half Round Tile File
Drill	Jigsaw & Suitable Blade (if work top cutout is required)
4mm Masonry Drill	Sharp Ended Nail Punch

INSTALLER

Please leave this leaflet with the user, as it contains valuable after care advice. These instructions are applicable to both Left Hand and Right Hand Drainer sinks.

NOTES

- **During installation, take care to protect the sink from scuffs and scratches.**
- **Do not stand on the sink.**
- **During installation, do not stand the sink on its edges or corners. This may cause damage.**
- **Avoid straining and over tightening of all plumbing fixtures connected to the sink.**
- **Carefully check that the moulding and edges of the sink are dead level so that water will flow off the drainer.**

PREPARING THE WORKTOP

Marking out the opening

We recommend that you fit the sink to the worktop before permanently fixing the worktop to the cabinet.

Decide the approximate position your sink is to be fitted, paying particular attention to where the taphole is to be fitted and proceed to cut your worktop and install your ceramic sink as follows:

1. Place the sink upside down on the worktop. Position the sink on the worktop as required. Make sure the cabinet framework will clear all parts of the sink. Using a soft, sharp pencil draw around the sink as accurately as possible (Fig 1). Remove the sink and check that the marked dimensions are the same as your sink.
2. For ceramic sinks installation, draw another line 10mm inside the sink top outline - this is the cutting line for the opening (Fig 2).
3. Drill as large a hole as possible inside the cutting line. Using a pad saw, jigsaw or similar, cut out the opening up to the cutting line.
4. Check that the sink fits in the cut-out, if it does not fit perfectly, some localised enlargement of the hole may be necessary.

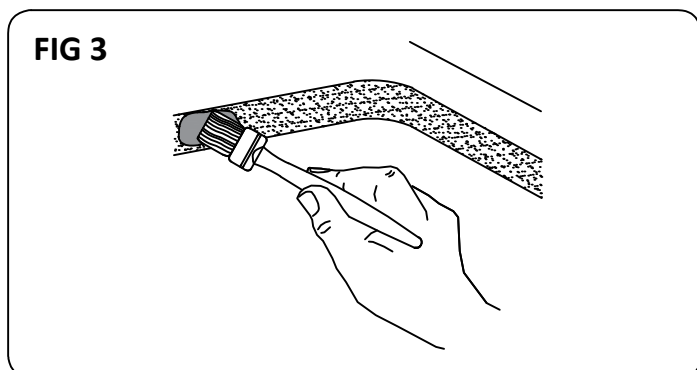
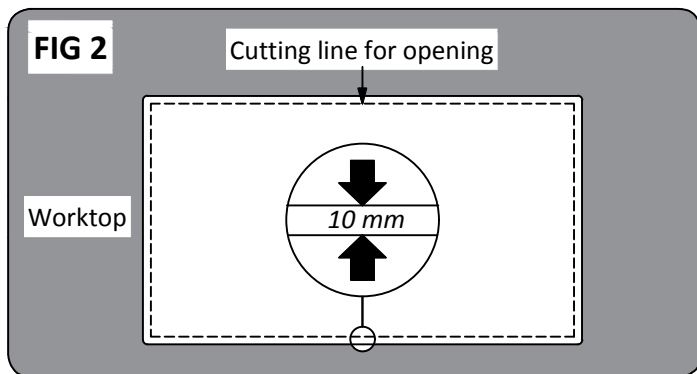
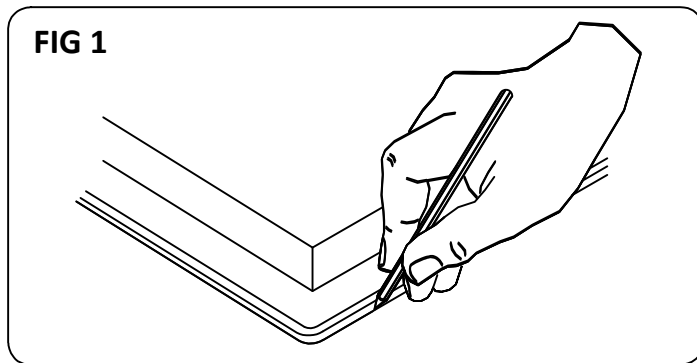

SEALING THE EDGES OF THE OPENING

We recommend that porous edges around the cut-out are sealed using a waterproof sealant such as varnish, paint or wood glue. This will prevent swelling of the worktop should any small leaks occur (Fig 3).

PREPARING THE TAP HOLE

It is highly recommended that safety goggles and gloves are worn when knocking through the tap hole.

We DO NOT recommend creating additional tap holes. Damage to the sink from attempting to create further tap holes will not be covered under warranty.

1. Choose the tap hole position based on the bowl and drainer orientation. This may be achieved by turning the sink upside down onto a suitable flat, well supported and protective and protective surface. You will see a 35mm part depth hole on either side of the sink. These are the tap holes.
2. After double-checking that you have chosen the correct tap position, you can begin work on creating the tap hole. Drill a 4mm hole with your masonry drill through the centre of the part removed hole with minimum force (Fig 4).

DO NOT USE HAMMER ACTION

3. After removing any debris from where you just drilled, carefully turn the sink over. Continue to use a strong, stable surface to support the drainer to allow further work.
4. Now working from the top face, in the centre of the 4mm tap hole use a pencil or non-permanent marker to mark the 35mm perimeter ring.
5. Place the sharp-ended nail in the centre of the 4mm hole. Using a hammer strike firmly the top of the punch until it has broken through. Work around the outer edge of the hole, with small repeated blows. Slowly increase the size of the hole until a round or half-round tile file can be inserted (Fig 5).
6. Carefully file away the remaining material to gradually enlarge the tap hole until you have removed the entire 35mm part-depth hole. Clear away any debris (Fig 6).

APPLYING THE SILCONE SEALANT

DO NOT use Epoxi sealant or Epoxi adhesive.

Silicone sealant may contain irritants and it is therefore advised the suitable Personal Protective Equipment is worn e.g. light weight rubber gloves, when the sink is sealed to the worktop.

1. If possible, it is best practice to have the tap installed, prior to sealing the sink to the worktop.
2. Apply a bead of 'kitchen silicone sealant' (not supplied) to the underside of the sink flange (Fig 7). Carefully position the sink into the worktop opening.
3. You may choose to neatly seal around the sink outer perimeter using silicone. Whilst the underside channel silicone bead should provide a watertight seal. Remove any surplus silicone sealant.

AFTER CARE

Although your sink is made from extremely durable materials and will withstand a great deal of hard use, it can be scratched by hard or sharp objects. If the surfaces are to be kept in a blemish free condition reasonable care should be taken when handling such items.

CLEANING

Never use any form of abrasive cleaner or applicator. The best way in our experience to keep your sparkling enamel surface is to apply a dilute solution of bleach every 2 or 3 days. Apply with a sponge or soft kitchen cloth and rinse the sink surface water. thoroughly with plenty of Not only will it make the surface shine but will also keep the sink hygenic.

Please do not over tighten any fittings as this may cause the surface of your ceramic sink to crack.

WASTE FITTINGS

Fit the waste fittings to the sink using the instructions supplied with them.

Do not overtighten waste outlets, pipework or taps as this may crack/chip the enamel surface

